

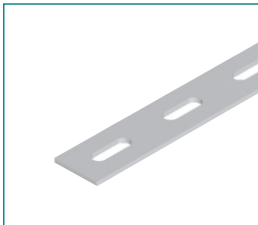
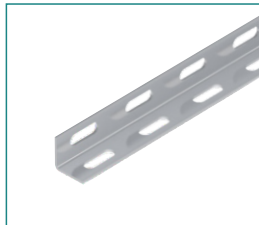
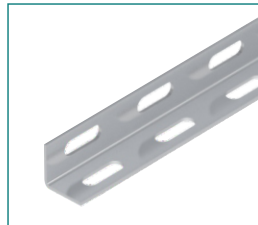
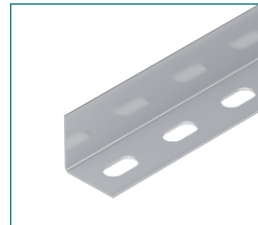
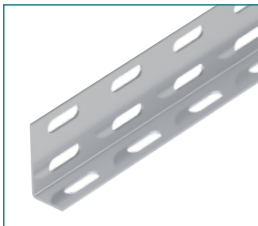
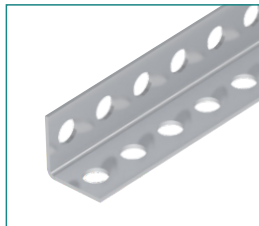
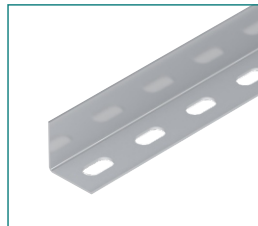
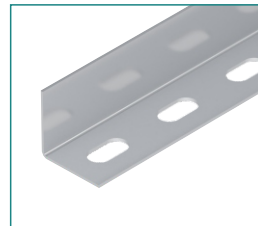
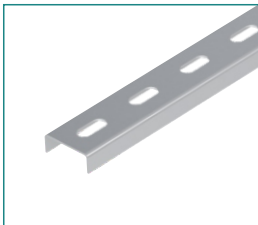
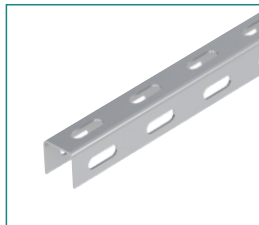
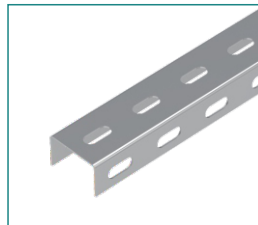
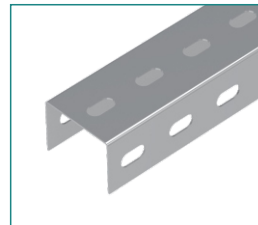
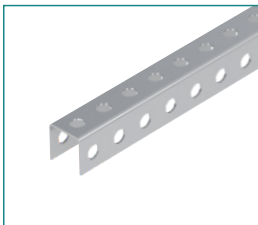
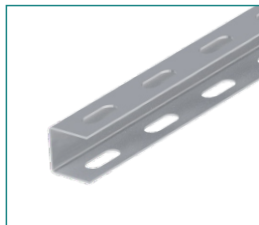
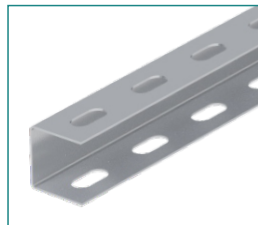

Profiles

 <p>SL 25 Hole: 8,5x25</p>	 <p>L..A Hole: 8,5x25</p>	 <p>LK..B Hole: 11x25</p>	 <p>LK..C Hole: 13x25</p>
 <p>LK..A Hole: 8,5x25</p>	 <p>L..F - LK..F Hole: Ø11</p>	 <p>LH..B Hole: 11x25</p>	 <p>LH..C Hole: 13x25</p>
 <p>UA Hole: 8,5x25</p>	 <p>UC..A Hole: 8,5x25</p>	 <p>UC..B Hole: 11x25</p>	 <p>UC..C Hole: 13x25</p>
 <p>UC..F Hole: Ø11</p>	 <p>UH..B Hole: 11x25</p>	 <p>UH..C Hole: 13x25</p>	 <p>OK Hole: 8X25</p>
 <p>CL..A Hole: 8x20+Ø11</p>	 <p>CL..C Hole: 13x25</p>	 <p>CL..F Hole: Ø11</p>	 <p>Z Hole: 11x25</p>
 <p>L8 Hole: 8x80</p>	 <p>U8 Hole: 8x80</p>	 <p>Z8 Hole: 8x80</p>	 <p>LP Hole: 8x80</p>

Flat Bar

Delikli Düz Lama - Перфорированная лента

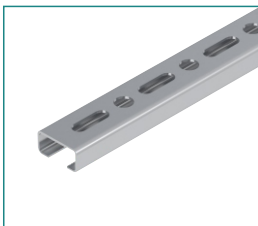
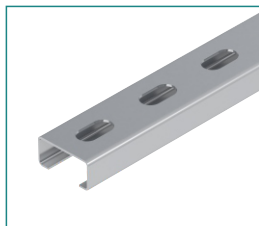
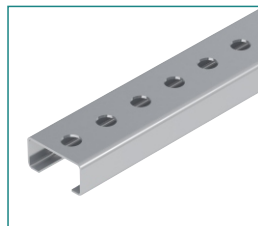
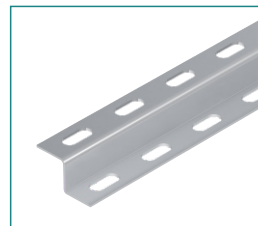
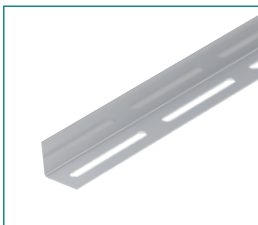
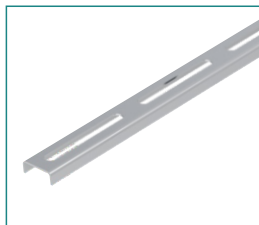
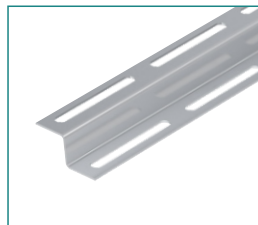
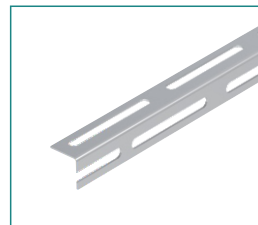
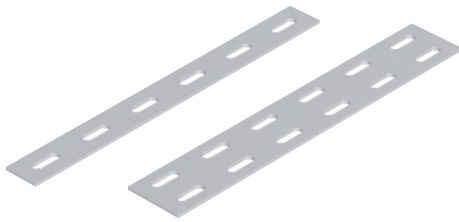

Pre-Galvanized EN 10346

SL		L:2000				
CODE	Width W mm	Thickness T mm	Hole Size mm	kg 1 mt	pcs	
SL 25A 20 PG	25	2.0	8,5x25	0.35	1	
SL 25A 30 PG	25	3.0	8,5x25	0.53	1	
SL 30A 20 PG	30	2.0	8,5x25	0.42	1	
SL 30A 30 PG	30	3.0	8,5x25	0.64	1	
SL 40A 20 PG	40	2.0	8,5x25	0.57	1	
SL 40A 30 PG	40	3.0	8,5x25	0.85	1	
SL 50A 20 PG	50	2.0	8,5x25	0.71	1	
SL 50A 30 PG	50	3.0	8,5x25	1.06	1	
SL 60A 20 PG	60	2.0	8,5x25	0.85	1	
SL 60A 30 PG	60	3.0	8,5x25	1.27	1	

Hot Dip Galvanized EN ISO 1461

SL		L:2000				
CODE	Width W mm	Thickness T mm	Hole Size mm	kg 1 mt	pcs	
SL 25A 20 HDG	25	2.0	8,5x25	0.39	1	
SL 25A 30 HDG	25	3.0	8,5x25	0.59	1	
SL 30A 20 HDG	30	2.0	8,5x25	0.47	1	
SL 30A 30 HDG	30	3.0	8,5x25	0.71	1	
SL 40A 20 HDG	40	2.0	8,5x25	0.63	1	
SL 40A 30 HDG	40	3.0	8,5x25	0.94	1	
SL 50A 20 HDG	50	2.0	8,5x25	0.79	1	
SL 50A 30 HDG	50	3.0	8,5x25	1.18	1	
SL 60A 20 HDG	60	2.0	8,5x25	0.94	1	
SL 60A 30 HDG	60	3.0	8,5x25	1.41	1	

L Profile

L Profil - L-образный профиль

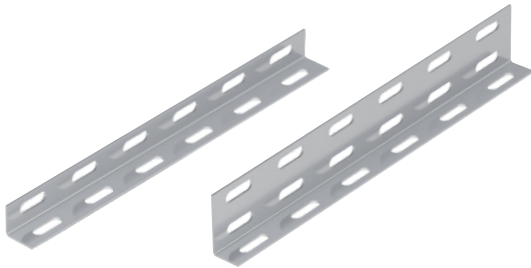

Pre-Galvanized EN 10346

L...A		L:2000				
CODE	Size mm HxW	Thickness T mm	Hole Size mm	kg 1 mt	pcs	
L 25A 15 PG	25x25	1.5	8,5x25	0.53	1	
L 25A 20 PG	25x25	2.0	8,5x25	0.71	1	
LK...B		L3000				
CODE	Size mm HxW	Thickness T mm	Hole Size mm	kg 1 mt	pcs	
LK 25B 15 PG	25x25	1.5	11x25	0.53	1	
LK 25B 20 PG	25x25	2.0	11x25	0.71	1	
LK 30B 15 PG	30x30	1.5	11x25	0.64	1	
LK 30B 20 PG	30x30	2.0	11x25	0.85	1	
LK 35B 15 PG	35x35	1.5	11x25	0.74	1	
LK 35B 20 PG	35x35	2.0	11x25	0.99	1	
LK 35B 30 PG	35x35	3.0	11x25	1.48	1	
LK...C		L3000				
CODE	Size mm HxW	Thickness T mm	Hole Size mm	kg 1 mt	pcs	
LK 40C 15 PG	40x40	1.5	13x25	0.85	1	
LK 40C 20 PG	40x40	2.0	13x25	1.13	1	
LK 40C 30 PG	40x40	3.0	13x25	1.70	1	
LK 50C 20 PG	50x50	2.0	13x25	1.41	1	
LK 50C 30 PG	50x50	3.0	13x25	2.12	1	
LK 50C 40 PG	50x50	4.0	13x25	2.83	1	
LK...A		L3000				
CODE	Size mm HxW	Thickness T mm	Hole Size mm	kg 1 mt	pcs	
LK 52A 15 PG	50x25	1.5	8,5x25	0.79	1	
LK 52A 20 PG	50x25	2.0	8,5x25	1.06	1	
LK 52A 25 PG	50x25	2.5	8,5x25	1.32	1	

Hot Dip Galvanized EN ISO 1461

L...A		L:2000				
CODE	Size mm HxW	Thickness T mm	Hole Size mm	kg 1 mt	pcs	
L 25A 15 HDG	25x25	1.5	8,5x25	0.59	1	
L 25A 20 HDG	25x25	2.0	8,5x25	0.79	1	
LK...B		L3000				
CODE	Size mm HxW	Thickness T mm	Hole Size mm	kg 1 mt	pcs	
LK 25B 15 HDG	25x25	1.5	11x25	0.59	1	
LK 25B 20 HDG	25x25	2.0	11x25	0.79	1	
LK 30B 15 HDG	30x30	1.5	11x25	0.71	1	
LK 30B 20 HDG	30x30	2.0	11x25	0.94	1	
LK 35B 15 HDG	35x35	1.5	11x25	0.82	1	
LK 35B 20 HDG	35x35	2.0	11x25	1.10	1	
LK 35B 30 HDG	35x35	3.0	11x25	1.65	1	
LK...C		L3000				
CODE	Size mm HxW	Thickness T mm	Hole Size mm	kg 1 mt	pcs	
LK 40C 15 HDG	40x40	1.5	13x25	0.94	1	
LK 40C 20 HDG	40x40	2.0	13x25	1.26	1	
LK 40C 30 HDG	40x40	3.0	13x25	1.88	1	
LK 50C 20 HDG	50x50	2.0	13x25	1.57	1	
LK 50C 30 HDG	50x50	3.0	13x25	2.36	1	
LK 50C 40 HDG	50x50	4.0	13x25	3.14	1	
LK...A		L3000				
CODE	Size mm HxW	Thickness T mm	Hole Size mm	kg 1 mt	pcs	
LK 52A 15 HDG	50x25	1.5	8,5x25	0.88	1	
LK 52A 20 HDG	50x25	2.0	8,5x25	1.18	1	
LK 52A 25 HDG	50x25	2.5	8,5x25	1.47	1	

SL 25

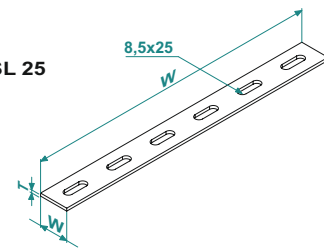

SL 50

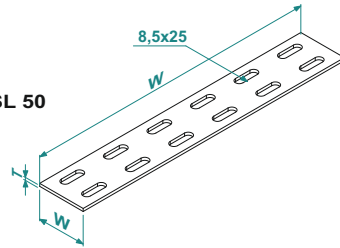

L...A

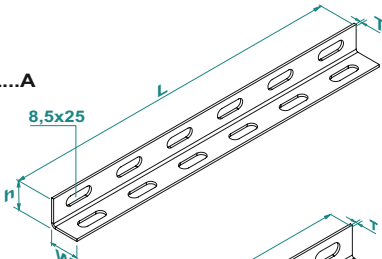

LK...B

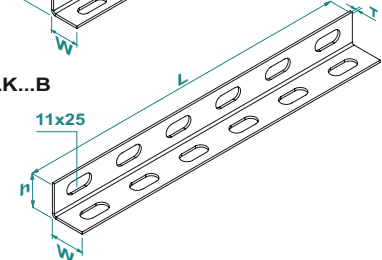

LK...C

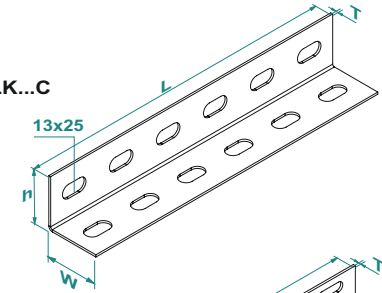

LK...A

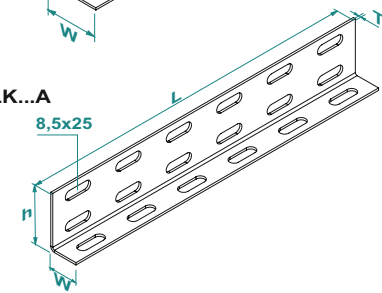

MATERIAL

Steel, strip-galv. acc. to the Sendzimir method to TS-EN 10346:2011 (PG)

HDG-steel, hot-dip galv. to TS-EN ISO 1461:2011 (HDG)

Available Finishes:

SS-Stainless steel AISI 304L and AISI 316L (SS)
EP-Powder coating in a full range of colours (RAL)

Thickn. (ga) [mm]: **1.5 2.0 2.5 3.0**

L Profile

L Profil - L-образный профиль

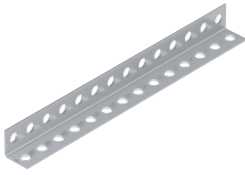

Pre-Galvanized EN 10346

L...F		L:2000				
CODE	Size mm HxW	Thickness T mm	Hole Size mm	kg 1mt	pcs	
L 30F 15 PG	30x30	1,5	Ø11	0.64	1	
L 30F 20 PG	30x30	2,0	Ø11	0.85	1	

LK...F		L:3000				
CODE	Size mm HxW	Thickness T mm	Hole Size mm	kg 1mt	pcs	
LK 30F 15 PG	30x30	1,5	Ø11	0.64	1	
LK 30F 20 PG	30x30	2,0	Ø11	0.85	1	

Hot Dip Galvanized EN ISO 1461

L...F		L:2000				
CODE	Size mm HxW	Thickness T mm	Hole Size mm	kg 1mt	pcs	
L 30F 15 HDG	30x30	1,5	Ø11	0.71	1	
L 30F 20 HDG	30x30	2,0	Ø11	0.94	1	

LK...F		L:3000				
CODE	Size mm HxW	Thickness T mm	Hole Size mm	kg 1mt	pcs	
LK 30F 15 HDG	30x30	1,5	Ø11	0.71	1	
LK 30F 20 HDG	30x30	2,0	Ø11	0.94	1	

L Profile

L Tipi Destek Profili - L-образный профиль

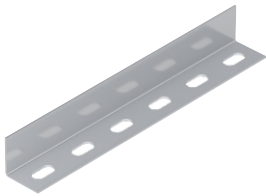

Pre-Galvanized EN 10346

LH...B		L:2000				
CODE	Size mm HxW	Thickness T mm	Hole Size mm	kg 1mt	pcs	
LH 25B 20 PG	25x25	2,0	11x25	0.71	1	
LH 30B 20 PG	30x30	2,0	11x25	0.85	1	
LH 30B 30 PG	30x30	3,0	11x25	1.27	1	

LH...C		L:2000				
CODE	Size mm HxW	Thickness T mm	Hole Size mm	kg 1mt	pcs	
LH 40C 30 PG	40x40	3,0	13x25	1.70	1	
LH 40C 40 PG	40x40	4,0	13x25	2.26	1	
LH 50C 30 PG	50x50	3,0	13x25	2.12	1	
LH 50C 40 PG	50x50	4,0	13x25	2.83	1	
LH 50C 50 EG	50x50	5,0	13x25	3.53	1	

Hot Dip Galvanized EN ISO 1461

LH...B		L:2000				
CODE	Size mm HxW	Thickness T mm	Hole Size mm	kg 1mt	pcs	
LH 25B 20 HDG	25x25	2,0	11x25	0.79	1	
LH 30B 20 HDG	30x30	2,0	11x25	0.94	1	
LH 30B 30 HDG	30x30	3,0	11x25	1.41	1	

LH...C		L:2000				
CODE	Size mm HxW	Thickness T mm	Hole Size mm	kg 1mt	pcs	
LH 40C 30 HDG	40x40	3,0	13x25	1.88	1	
LH 40C 40 HDG	40x40	4,0	13x25	2.51	1	
LH 50C 30 HDG	50x50	3,0	13x25	2.36	1	
LH 50C 40 HDG	50x50	4,0	13x25	3.14	1	
LH 50C 50 HDG	50x50	5,0	13x25	3.93	1	

U Profile

U Profil - U-образный профиль

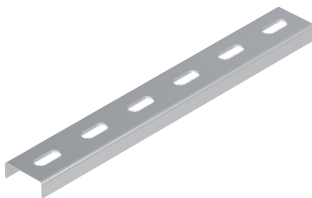

Pre-Galvanized EN 10346

UA		L:1000				
CODE	Size mm HxW	Thickness T mm	Hole Size mm	kg 1mt	pcs	
UA 2812A.10 12 PG	12x28	1,2	8,5x25	0.43	1	

UA		L:2000				
CODE	Size mm HxW	Thickness T mm	Hole Size mm	kg 1mt	pcs	
UA 2812A 12 PG	12x28	1,2	8,5x25	0.43	1	

UA...B		L:2000				
CODE	Size mm HxW	Thickness T mm	Hole Size mm	kg 1mt	pcs	
UA 4015B 15 PG	15x40	1,5	11x25	0.74	1	
UA 4015B 20 PG	15x40	2,0	11x25	0.99	1	
UA 4020B 20 PG	15x40	2,0	11x25	0.99	1	

UA...F		L:2000				
CODE	Size mm HxW	Thickness T mm	Hole Size mm	kg 1mt	pcs	
UA 3515F 15 PG	15x35	1,5	Ø11	0.69	1	

Hot Dip Galvanized EN ISO 1461

UA		L:1000				
CODE	Size mm HxW	Thickness T mm	Hole Size mm	kg 1mt	pcs	
UA 2812A.10 12 HDG	12x28	1,2	8,5x25	0.48	1	

UA		L:2000				
CODE	Size mm HxW	Thickness T mm	Hole Size mm	kg 1mt	pcs	
UA 2812A 12 HDG	12x28	1,2	8,5x25	0.48	1	

UA...B		L:2000				
CODE	Size mm HxW	Thickness T mm	Hole Size mm	kg 1mt	pcs	
UA 4015B 15 HDG	15x40	1,5	11x25	0.82	1	
UA 4015B 20 HDG	15x40	2,0	11x25	1.10	1	
UA 4020B 20 HDG	15x40	2,0	11x25	1.10	1	

UA...F		L:2000				
CODE	Size mm HxW	Thickness T mm	Hole Size mm	kg 1mt	pcs	
UA 3515F 15 HDG	15x35	1,5	Ø11	0.77	1	

L...F - LK...F

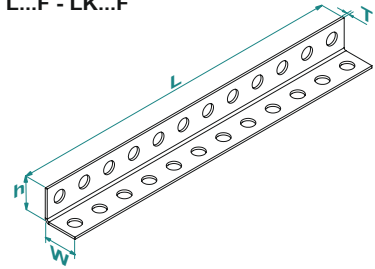

LH...B

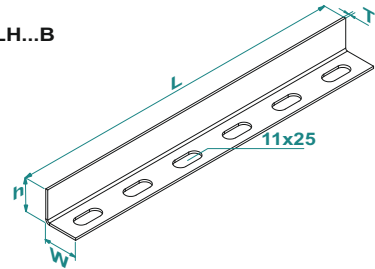

LH...C

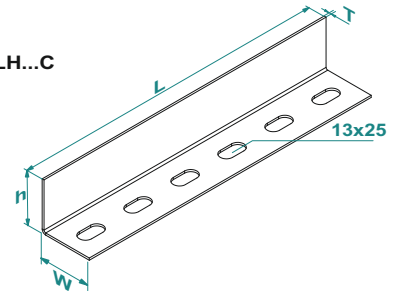

UA

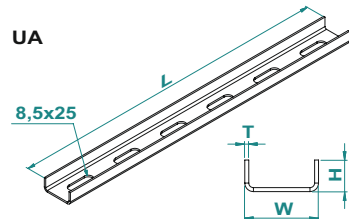

UA...B

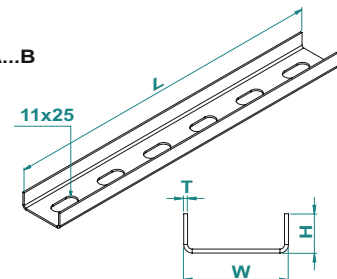

MATERIAL

Steel, strip-galv. acc. to the sendzimir method to TS-EN 10346:2011 (PG)

HDG-Steel, hot-dip galv. to TS-EN ISO 1461:2011 (HDG)

Available finishes:

SS - Stainless steel AISI 304L and aisi 316L (SS)
EP - powder coating in a full range of colours (RAL)

Thickn. (ga) [mm]: 1.5 2.0 2.5 3.0

U Profile

U Profil - U-образный профиль

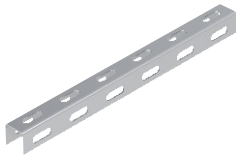

Pre-Galvanized EN 10346

UC...A		L:2000				
CODE	Size mm HxW	Thickness T mm	Hole Size mm	kg 1mt	pcs	
UC 2525A 15 PG	25x25	1,5	8,5x25	0,79	1	
UC 2525A 20 PG	25x25	2,0	8,5x25	1,06	1	
UC...B		L:3000				
UC 4030B 15 PG	30x40	1,5	11x25	1,06	1	
UC 4030B 20 PG	30x40	2,0	11x25	1,41	1	
UC 4335B 20 PG	35x43	2,0	11x25	1,60	1	
UC 4335B 25 PG	35x43	2,5	11x25	2,00	1	
UC...C		L:3000				
UC 5040C 20 PG	40x50	2,0	13x25	1,84	1	
UC 5040C 30 PG	40x50	3,0	13x25	2,76	1	
UC 6040C 25 PG	40x60	2,5	13x25	2,47	1	
UC 6040C 30 PG	40x60	3,0	13x25	2,97	1	
UC 7050C 30 PG	50x70	3,0	13x25	3,60	1	
UC 7050C 40 PG	50x70	4,0	13x25	4,80	1	

Hot Dip Galvanized EN ISO 1461

UC...A		L:2000				
CODE	Size mm HxW	Thickness T mm	Hole Size mm	kg 1mt	pcs	
UC 2525A 15 HDG	25x25	1,5	8,5x25	0,88	1	
UC 2525A 20 HDG	25x25	2,0	8,5x25	1,18	1	
UC...B		L:3000				
UC 4030B 15 HDG	30x40	1,5	11x25	1,18	1	
UC 4030B 20 HDG	30x40	2,0	11x25	1,57	1	
UC 4335B 20 HDG	35x43	2,0	11x25	1,77	1	
UC 4335B 25 HDG	35x43	2,5	11x25	2,22	1	
UC...C		L:3000				
UC 5040C 20 HDG	40x50	2,0	13x25	2,04	1	
UC 5040C 30 HDG	40x50	3,0	13x25	3,06	1	
UC 6040C 25 HDG	40x60	2,5	13x25	2,75	1	
UC 6040C 30 HDG	40x60	3,0	13x25	3,30	1	
UC 7050C 30 HDG	50x70	3,0	13x25	4,00	1	
UC 7050C 40 HDG	50x70	4,0	13x25	5,34	1	

U Profile

U Profil - U-образный профиль

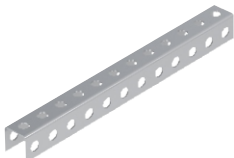

Pre-Galvanized EN 10346

UC...F		L:3000				
CODE	Size mm HxW	Thickness T mm	Hole Size mm	kg 1mt	pcs	
UC 3030F 20 PG	30x30	2,0	Ø11	1,27	1	
UC 3030F 25 PG	30x30	2,5	Ø11	1,59	1	
UC 3030F 30 PG	30x30	3,0	Ø11	1,91	1	
UC...E		L:3000				
UC 4040E 20 PG	40x40	2,0	Ø13	1,70	1	
UC 4040E 25 PG	40x40	2,5	Ø13	2,12	1	
UC 4040E 30 PG	40x40	3,0	Ø13	2,54	1	
UC 4040E 40 PG	40x40	4,0	Ø13	3,39	1	
UC 6040E 25 PG	40x60	2,5	Ø13	2,47	1	
UC 6040E 30 PG	40x60	3,0	Ø13	2,97	1	
UC 6040E 40 PG	40x60	4,0	Ø13	3,96	1	

Hot Dip Galvanized EN ISO 1461

UC...F		L:3000				
CODE	Size mm HxW	Thickness T mm	Hole Size mm	kg 1mt	pcs	
UC 3030F 20 HDG	30x30	2,0	Ø11	1,41	1	
UC 3030F 25 HDG	30x30	2,5	Ø11	1,77	1	
UC 3030F 30 HDG	30x30	3,0	Ø11	2,12	1	
UC...E		L:3000				
UC 4040E 20 HDG	40x40	2,0	Ø13	1,88	1	
UC 4040E 25 HDG	40x40	2,5	Ø13	2,36	1	
UC 4040E 30 HDG	40x40	3,0	Ø13	2,83	1	
UC 4040E 40 HDG	40x40	4,0	Ø13	3,77	1	
UC 6040E 25 HDG	40x60	2,5	Ø13	2,75	1	
UC 6040E 30 HDG	40x60	3,0	Ø13	3,30	1	
UC 6040E 40 HDG	40x60	4,0	Ø13	4,40	1	

U Profile

U Profil - U-образный профиль

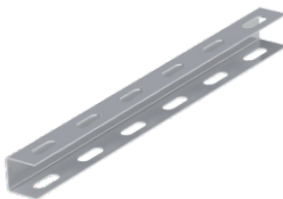

EG:Electro-Galvanised / PG:Pregalvanized

UH...B		L:2000				
CODE	Size mm HxW	Thickness T mm	Hole Size mm	kg 1mt	pcs	
UH 3023B 20 PG	23x30	2,0	11x25	1,07	1	
UH 3030B 30 PG	30x30	3,0	11x25	1,91	1	
UH...C		L:2000				
UH 4040C 30 EG	40x40	3,0	13x25	2,54	1	
UH 4040C 40 EG	40x40	4,0	13x25	3,39	1	
UH 5050C 30 EG	50x50	3,0	13x25	3,18	1	
UH 5050C 40 EG	50x50	4,0	13x25	4,24	1	

Hot Dip Galvanized EN ISO 1461

UH...B		L:2000				
CODE	Size mm HxW	Thickness T mm	Hole Size mm	kg 1mt	pcs	
UC 3023B 20 HDG	23x30	2,0	11x25	1,19	1	
UC 3030B 30 HDG	30x30	3,0	11x25	2,12	1	
UH...C		L:2000				
UC 4040C 30 HDG	40x40	3,0	13x25	2,83	1	
UC 4040C 40 HDG	40x40	4,0	13x25	3,77	1	
UC 5050C 30 HDG	50x50	3,0	13x25	3,53	1	
UC 5050C 40 HDG	50x50	4,0	13x25	4,71	1	

UC...A

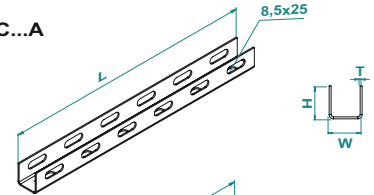

UC...B

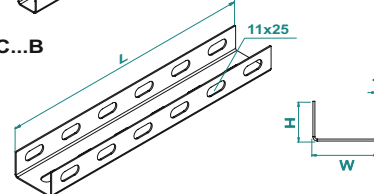

UC...C

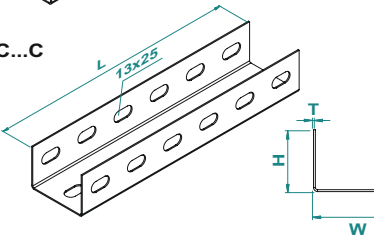

UC...F

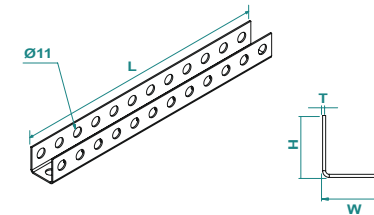

UC...E

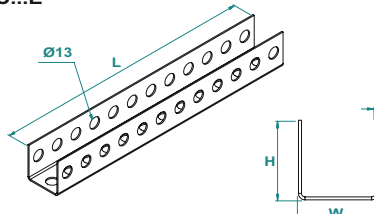

UH...B

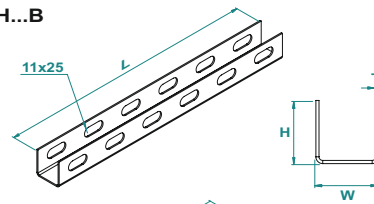

UH...C

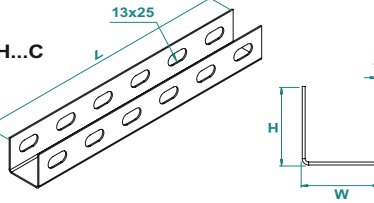

MATERIAL

Steel, strip-galv. acc. to the sendzimir method to TS-EN 10346:2011 (PG)

HDG-Steel, hot-dip galv. to TS-EN ISO 1461:2011 (HDG)

Available finishes:

SS - Stainless steel AISI 304L and aisi 316L (SS)
EP - powder coating in a full range of colours (RAL)

Thickn. (ga) [mm]: 1.5 2.0 2.5 3.0

Hanging C Rail

Askı Profili - C-образный профиль

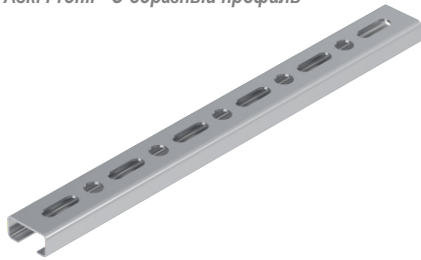

Pre-Galvanized EN 10346

CL...A		L:2000				
CODE	Size mm HxW	Thickness T mm	Hole Size mm	kg 1mt	pcs	
CL 2715A 10 PG	15x27	1,0	8,5x20	0.49	1	
CL 2715A 12 PG	15x27	1,2	8,5x20	0.58	1	
CL 2718A 10 PG	18x27	1,0	8,5x20	0.53	1	
CL 2718A 12 PG	18x27	1,2	8,5x20	0.63	1	
CL 3015A 12 PG	15x30	1,2	8,5x20	0.60	1	
CL 3015A 15 PG	15x30	1,5	8,5x20	0.74	1	
CL 3020A 15 PG	20x30	1,5	8,5x20	0.85	1	
CL 3028A 15 PG	28x30	1,5	8,5x20	1.02	1	

Hot Dip Galvanized EN ISO 1461

CL...A		L:2000				
CODE	Size mm HxW	Thickness T mm	Hole Size mm	kg 1mt	pcs	
CL 2715A 10 HDG	15x27	1,0	8,5x20	0.54	1	
CL 2715A 12 HDG	15x27	1,2	8,5x20	0.64	1	
CL 2718A 10 HDG	18x27	1,0	8,5x20	0.59	1	
CL 2718A 12 HDG	18x27	1,2	8,5x20	0.70	1	
CL 3015A 12 HDG	15x30	1,2	8,5x20	0.67	1	
CL 3015A 15 HDG	15x30	1,5	8,5x20	0.82	1	
CL 3020A 15 HDG	20x30	1,5	8,5x20	0.94	1	
CL 3028A 15 HDG	28x30	1,5	8,5x20	1.13	1	

CL...A

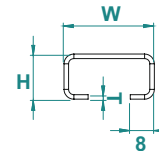
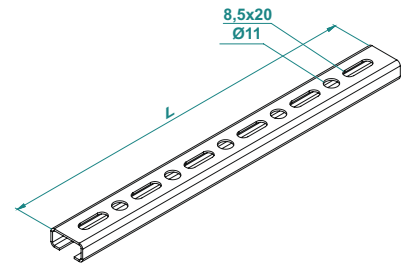

Hanging C Rail

Askı Profili - C-образный профиль

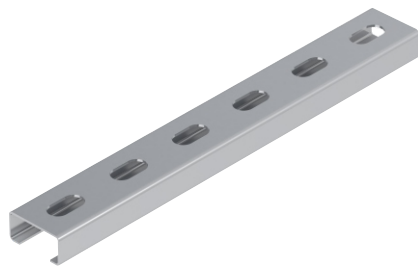

Pre-Galvanized EN 10346

CL...C		L:3000				
CODE	Size mm HxW	Thickness T mm	Hole Size mm	kg 1mt	pcs	
CL 4020C 15 PG	20x40	1,5	13x25	1.00	1	
CL 4020C 20 PG	20x40	2,0	13x25	1.30	1	
CL 4038C 15 PG	38x40	1,5	13x25	1.38	1	
CL 4038C 20 PG	38x40	2,0	13x25	1.81	1	
CL 5040C 20 PG	40x50	2,0	13x25	2.01	1	
CL 6040C 20 PG	40x60	2,0	13x25	2.15	1	

Hot Dip Galvanized EN ISO 1461

CL...C		L:3000				
CODE	Size mm HxW	Thickness T mm	Hole Size mm	kg 1mt	pcs	
CL 4020C 15 HDG	20x40	1,5	13x25	1.11	1	
CL 4020C 20 HDG	20x40	2,0	13x25	1.44	1	
CL 4038C 15 HDG	38x40	1,5	13x25	1.53	1	
CL 4038C 20 HDG	38x40	2,0	13x25	2.01	1	
CL 5040C 20 HDG	40x50	2,0	13x25	2.23	1	
CL 6040C 20 HDG	40x60	2,0	13x25	2.39	1	

CL...C

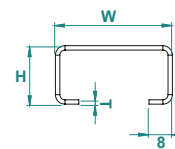
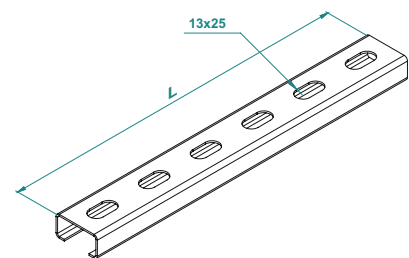

Hanging C Rail

Askı Profili - C-образный профиль

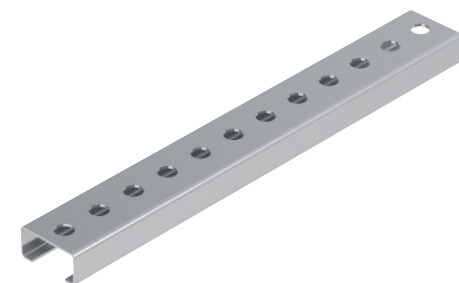

Pre-Galvanized EN 10346

CL...F		L:3000				
CODE	Size mm HxW	Thickness T mm	Hole Size mm	kg 1mt	pcs	
CL 4020F 12 PG	20x40	1,2	Ø11	0.81	1	
CL 4020F 15 PG	20x40	1,5	Ø11	1.00	1	
CL 4020F 20 PG	20x40	2,0	Ø11	1.30	1	

Hot Dip Galvanized EN ISO 1461

CL...F		L:3000				
CODE	Size mm HxW	Thickness T mm	Hole Size mm	kg 1mt	pcs	
CL 4020F 12 HDG	20x40	1,2	Ø11	0.90	1	
CL 4020F 15 HDG	20x40	1,5	Ø11	1.11	1	
CL 4020F 20 HDG	20x40	2,0	Ø11	1.44	1	

CL...F

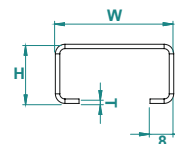
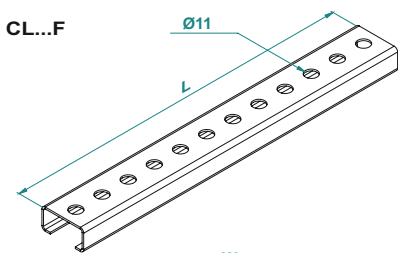

MATERIAL

Steel, strip-galv. acc. to the sendzimir method to TS-EN 10346:2011 (PG)

HDG-Steel, hot-dip galv. to TS-EN ISO 1461:2011 (HDG)

Available finishes:

SS - Stainless steel AISI 304L and aisi 316L (SS)
EP- powder coating in a full range of colours (RAL)

Thickn. (ga) [mm]: 1.5 2.0 2.5 3.0

Z Profile

Z Profil - Z-образный профиль

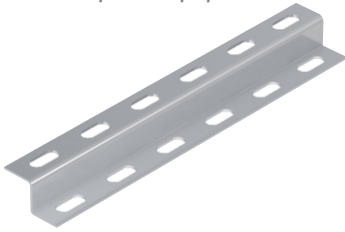

Pre-Galvanized EN 10346

Z		L:2000				
CODE	Size mm AxHxA	Thickness T mm	Hole Size mm	kg 1mt	pcs	
Z 222 15 PG	25x25x25	1,5	11x25	0.79	1	
Z 222 20 PG	25x25x25	2,0	11x25	1.06	1	
Z 242 15 PG	25x25x25	1,5	11x25	0.95	1	
Z 333 20 PG	25x25x25	2,0	11x25	1.27	1	
Z 343 20 PG	25x25x25	2,0	11x25	1.41	1	

Hot Dip Galvanized EN ISO 1461

Z		L:2000				
CODE	Size mm AxHxA	Thickness T mm	Hole Size mm	kg 1mt	pcs	
Z 222 15 HDG	25x25x25	1,5	11x25	0.88	1	
Z 222 20 HDG	25x25x25	2,0	11x25	1.18	1	
Z 242 15 HDG	25x25x25	1,5	11x25	1.06	1	
Z 333 20 HDG	25x25x25	2,0	11x25	1.41	1	
Z 343 20 HDG	25x25x25	2,0	11x25	1.57	1	

Z Profile

Z Tipi Destek Profili - Z-образный профиль

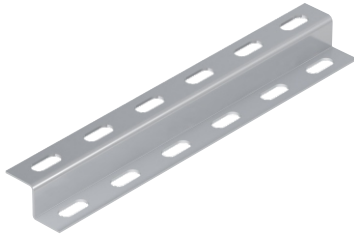

Pre-Galvanized EN 10346

ZK		L:3000				
CODE	Size mm AxHxA	Thickness T mm	Hole Size mm	kg 1mt	pcs	
ZK 222 12 PG	25x25x25	1,2	11x25	0.64	1	
ZK 222 15 PG	25x25x25	1,5	11x25	0.79	1	
ZK 222 20 PG	25x25x25	2,0	11x25	1.06	1	
ZK 242 15 PG	25x40x25	1,5	11x25	0.95	1	
ZK 242 20 PG	25x40x25	2,0	11x25	1.27	1	
ZK 252 15 PG	25x50x25	1,5	11x25	1.06	1	
ZK 252 20 PG	25x50x25	2,0	11x25	1.41	1	
ZK 333 20 PG	30x30x30	2,0	11x25	1.27	1	
ZK 343 20 PG	30x40x30	2,0	11x25	1.41	1	
ZK 424 20 PG	40x25x40	2,0	11x25	1.48	1	
ZK 424 30 PG	40x25x40	3,0	11x25	2.23	1	
ZK 444 20 PG	40x40x40	2,0	11x25	1.70	1	
ZK 444 30 PG	40x40x40	3,0	11x25	2.54	1	
ZK 464 20 PG	40x60x40	2,0	11x25	1.98	1	
ZK 464 30 PG	40x60x40	3,0	11x25	2.97	1	
ZK 464 40 PG	40x60x40	4,0	11x25	3.96	1	
ZK 555 20 PG	50x50x50	2,0	11x25	2.12	1	
ZK 555 30 PG	50x50x50	3,0	11x25	3.18	1	
ZK 555 40 PG	50x50x50	4,0	11x25	4.24	1	

Hot Dip Galvanized EN ISO 1461

ZK		L:3000				
CODE	Size mm AxHxA	Thickness T mm	Hole Size mm	kg 1mt	pcs	
ZK 222 12 HDG	25x25x25	1,2	11x25	0.71	1	
ZK 222 15 HDG	25x25x25	1,5	11x25	0.88	1	
ZK 222 20 HDG	25x25x25	2,0	11x25	1.18	1	
ZK 242 15 HDG	25x40x25	1,5	11x25	1.06	1	
ZK 242 20 HDG	25x40x25	2,0	11x25	1.41	1	
ZK 252 15 HDG	25x50x25	1,5	11x25	1.18	1	
ZK 252 20 HDG	25x50x25	2,0	11x25	1.57	1	
ZK 333 20 HDG	30x30x30	2,0	11x25	1.41	1	
ZK 343 20 HDG	30x40x30	2,0	11x25	1.57	1	
ZK 424 20 HDG	40x25x40	2,0	11x25	1.65	1	
ZK 424 30 HDG	40x25x40	3,0	11x25	2.47	1	
ZK 444 20 HDG	40x40x40	2,0	11x25	1.88	1	
ZK 444 30 HDG	40x40x40	3,0	11x25	2.83	1	
ZK 464 20 HDG	40x60x40	2,0	11x25	2.20	1	
ZK 464 30 HDG	40x60x40	3,0	11x25	3.30	1	
ZK 464 40 HDG	40x60x40	4,0	11x25	4.40	1	
ZK 555 20 HDG	50x50x50	2,0	11x25	2.36	1	
ZK 555 30 HDG	50x50x50	3,0	11x25	3.53	1	
ZK 555 40 HDG	50x50x50	4,0	11x25	4.71	1	

Ω Profile

Ω Tipi Destek Profili - Ω-образный профиль

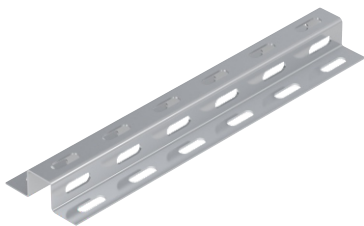

Pre-Galvanized EN 10346

OK		L:3000				
CODE	Size mm AxHxB	Thickness T mm	Hole Size mm	kg 1mt	pcs	
OK 222 20 PG	25x25x25	2,0	8x25	1.76	1	
OK 225 20 PG	25x25x25	2,0	8x25	2.12	1	
OK 255 20 PG	25x25x25	2,0	8x25	2.83	1	

Hot Dip Galvanized EN ISO 1461

OK		L:3000				
CODE	Size mm AxHxB	Thickness T mm	Hole Size mm	kg 1mt	pcs	
OK 222 20 HDG	25x25x25	2,0	8x25	1.76	1	
OK 225 20 HDG	25x25x25	2,0	8x25	2.12	1	
OK 255 20 HDG	25x25x25	2,0	8x25	2.83	1	

Z

ZK

OK

MATERIAL

PG- Sendzimir Method to TS-EN 10346:2011
 HDG-Steel, hot-dip galv. to TS-EN ISO 1461:2011 (HDG)

Available finishes:
 SS - Stainless steel AISI 304L and aisi 316L (SS)
 EP- powder coating in a full range of colours (RAL)

Thickn. (ga) [mm]: **1.5 2.0 2.5 3.0**

L Profile

L Profil - L-образный профиль



Pre-Galvanized EN 10346

L8		L:2000				
CODE	Size mm HxW	Thickness T mm	Hole Size mm	KG 1mt	pcs	
L8 2525 20 PG	25x25	2,0	8x80	0.71	1	
L8 3030 30 PG	30x30	3,0	8x80	1.34	1	
L8 4040 30 PG	40x40	3,0	8x80	1.74	1	

Electro-Galvanised

L8		L:2000				
CODE	Size mm HxW	Thickness T mm	Hole Size mm	KG 1mt	pcs	
L8 2525 20 EG	25x25	2,0	8x80	0.71	1	
L8 3030 30 EG	30x30	3,0	8x80	1.34	1	
L8 4040 30 EG	40x40	3,0	8x80	1.74	1	

U Profile

U Profil - U-образный профиль



Pre-Galvanized EN 10346

U8		L:2000				
CODE	Size mm HxW	Thickness T mm	Hole Size mm	KG 1mt	pcs	
U8 2510 20 PG	10x25	2,0	8x80	0.71	1	
U8 4012 20 PG	12x40	2,0	8x80	0.94	1	

Electro-Galvanised

U8		L:2000				
CODE	Size mm HxW	Thickness T mm	Hole Size mm	KG 1mt	pcs	
U8 2510 20 EG	10x25	2,0	8x80	0.71	1	
U8 4012 20 EG	12x40	2,0	8x80	0.94	1	

Z Profile

Z Profil - Z-образный профиль

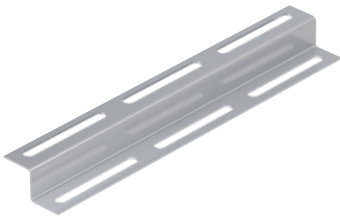

Pre-Galvanized EN 10346

Z8		L:2000				
CODE	Size mm AxHxA	Thickness T mm	Hole Size mm	KG 1mt	pcs	
Z8 222 20 PG	25x25x25	2,0	8x80	1.05	1	
Z8 333 30 PG	30x30x30	3,0	8x80	1.84	1	
Z8 444 30 PG	40x40x40	3,0	8x80	2.54	1	
Z8 555 30 PG	50x50x50	3,0	8x80	3.53	2	

Electro-Galvanised

Z8		L:2000				
CODE	Size mm AxHxA	Thickness T mm	Hole Size mm	KG 1mt	pcs	
Z8 222 20 EG	25x25x25	2,0	8x80	1.05	1	
Z8 333 30 EG	30x30x30	3,0	8x80	1.84	1	
Z8 444 30 EG	40x40x40	3,0	8x80	2.54	1	
Z8 555 30 EG	50x50x50	3,0	8x80	3.53	2	

L Profile

L Profil - L-образный профиль

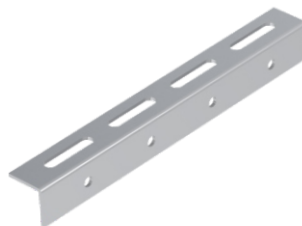
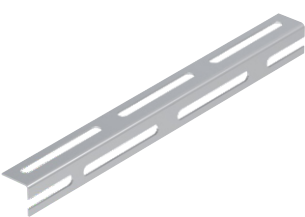

Pre-Galvanized EN 10346

LP		L:2000				
CODE	Size mm H x W	Thickness T mm	Hole Size mm	KG 1mt	pcs	
LP 2525 20 PG	25x25	2,0	8x80	0.71	1	

Pre-Galvanised EN 10346

LPO		L:2000				
CODE	Size mm H x W	Thickness T mm	Hole Size mm	KG 1mt	pcs	
LPO 2525 20 PG	25x25	2,0	8x37-Ø6	0.71	1	

L8

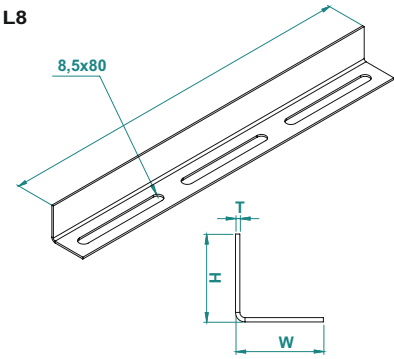

U8

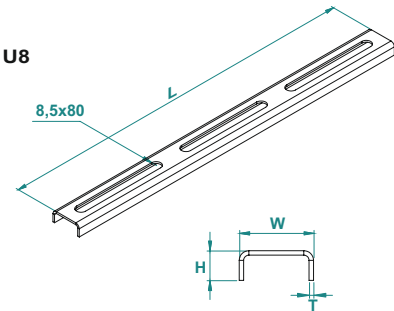

Z8

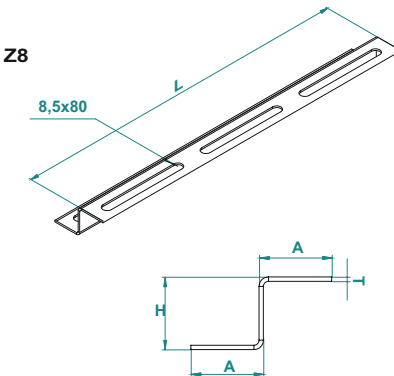

LP

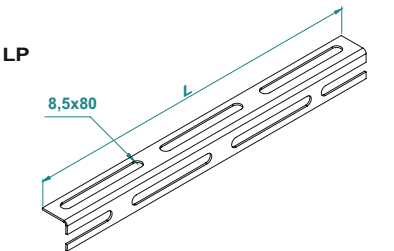

LPO

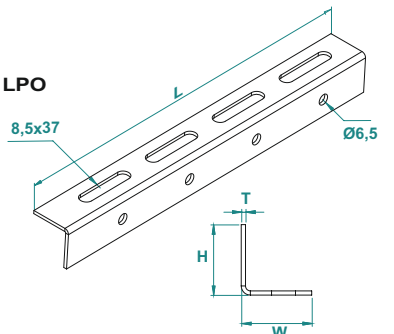

MATERIAL

PG- Sendzmir Method to TS-EN 10346:2011

EG- Electro-Galvanised EN ISO 2081

Thickn. (ga) [mm]: 1.5 2.0 2.5 3.0